

SAFETY and QUICKNESS

The AIJGO testers make 2 testing processes per sec. Left foot, Right foot and wrist strap tests have different testing circles but the tester make them at the same time. When the 2 testing processes have Pass results only this case the tester give Pass information. This double testing mode provides high safety testing results.

ACCURACY and RELIABILITY

The AIJGO testers use 40 V test voltage to avoid false test results. Under 40 V test voltage the test results are not safety because of the dirt and the contamination on the sole of the ESD shoes or heel grounders. it can lose false test results. The 40 V test voltage provides a reliable and accurate tester.

VERSATILE and FLEXIBLE

All AIJGO testers have Relay Output to open any kind of entrance gate (tripod turnstile, swing gate, wing barrier,...). Not need to change the tester if entrance gate is required to install. The tester have to be connected only by a cable to the gate



LIGHT BAR System

This unique system with the LED lighting signal is an ideal solution for high volume of entrances where the quickness and safety is very important. The high damaging-resistant construction with the steel touch-button can prevent the frequent failures of any kind of push-button. The operators only have to touch the button, they do not need to push it. The LIGHT BAR system is developed for multinational companies which require many thousand of entrance per day. The 12 pcs energy saving LED have strong visual effect for the operator to inform the test result. It can distinguish the test result of the wrist strap, left and right foot (Pass – Green, Fail – Red):

LIGHT BAR System standby mode



LIGHT BAR System working modes *



* WS: wrist strap, LF: left feet, RF: right feet

COMFORT System

This system is a perfect choice where the personal identification is an important side of the entrance process to the ESD area. The identification is detected by a RFID reader where the operators use a Personal Chip Card. The test results and the identification data are transferred to a PC which has a Management Software. It makes to read and save the data possible, furthermore to set parameters. The COMFORT system provides a fully automatic solution for entrance to the ESD area and the data-processing (personal identification, test results).

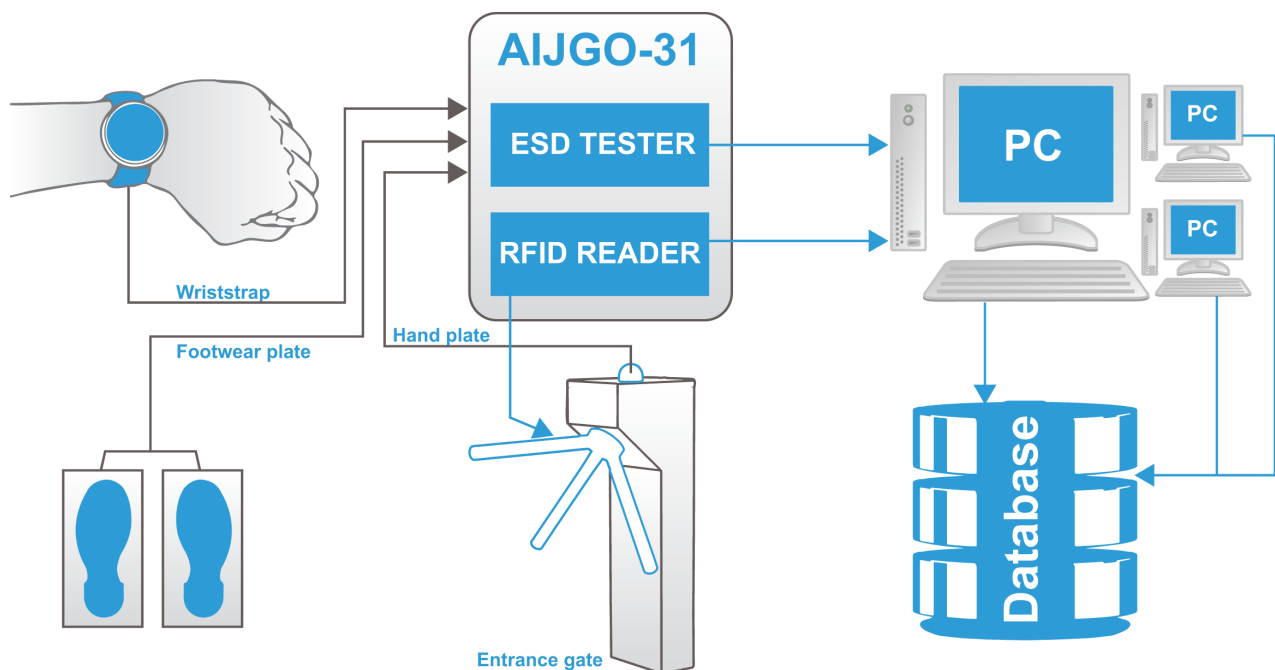

COMFORT 
s y s t e m

RFID reader

It can read the information from the Personal Chip Card which contains the personal identification and the test method on the basis of the tester make the test (Only footwear testing or footwear and wrist strap combined testing or VIP). The test starts after the card reading in any case so the operator cannot entry to the ESD area without identification after a successful test.

Management Software

It handles the identification data of the operators, uploading the operators's data from data base or manually. Test method choosing to the operators (Only footwear testing or footwear and wrist strap combined testing or VIP). The software controls the AIJGO-31LB/ALU tester. It can control max. 72 pcs tester and 24 pcs PC. It saves the entrance data to local .csv file (compatible with EXCEL and text editors). Automatically It cuts now log file every day. Acceptance limits changeable by the software. If the PC is connected to LAN network, the Management software is available on the internet.

Network solution

If the ESD area has more than one entrance and personal identification needed in this case more ESD testers are required with RFID reader to all entrance. There is possibility to connect the testers and PC's into the same network and to manage the same software. Max. 3 pcs AIJGO-31LB/ALU testers are operated by one PC and Management Software.(Max. distance between the PC and tester is 100 m)



If more that 3 AIJGO-31LB/ALU testers are needed to connect in this case LAN network required: Max. 24 pcs PC are handle in the LAN network so Max. 72 pcs AIJGO-31LB/ALU testers are possible to connect.

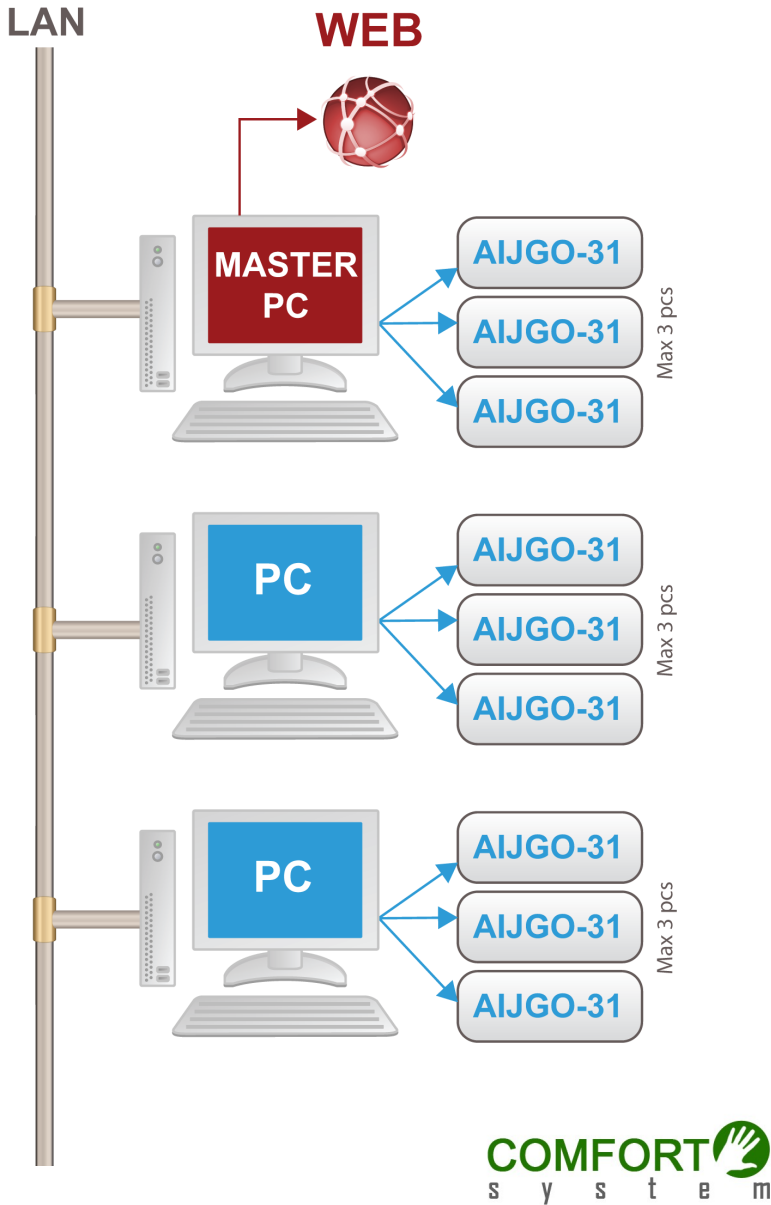

COMPLEX System

This system provides an „all in one” solution with our tripod turnstile. It is a „build-in” construction because the AIJGO testers and Dual Foot Electrode are built in and installed into the gate. It is not required any extra installation knowledge. Properties of the gate:

- ⇒ Manual rotation with mechanical support
- ⇒ Rotation blockable electrically
- ⇒ Mechanical brake system
- ⇒ Electrically controlled arm fall system (fire alarm)
- ⇒ In this case power cut, the arm system freely rotate to give fast transit
- ⇒ Indoor use only

COMPLEX
s y s t e m



AIJGO-22/ALU Footwear & Wrist Strap Tester with Dual Foot Electrode

The AIJGO-22/ALU is an easy usable Footwear & Wrist strap tester to entrance of EPA area. It is versatile tester because you can choose the right measuring methods according to entrance regulation: Only footwear testing or footwear and wrist strap combined testing. You have to make only one test at the same time for the left and right foot because of the dual foot electrode. It can be connected to any kind of entrance gate (tripod turnstile, swing gate, wing barrier,...) with a relay output. It can be installed on the wall or with stand to the floor.

- ⇒ Footwear and Wrist Strap Tester for ESD area entrance
- ⇒ Both foot and wrist strap testing at the same time
- ⇒ Dual foot electrode to test the right and left foot separately
- ⇒ Test selector: Only footwear testing or Footwear and wrist strap combined testing
- ⇒ Resistance limits set by Software:

Footwear: 100 K Ω - 35 M Ω - Wrist Strap: 750 K Ω - 35 M Ω

- ⇒ Compliance with IEC 61340-5-1 and ANSI/ESD S20.20
- ⇒ Light (LED) and sound signal for the pass and faulty test, results separately:

Wrist Strap - Left foot - Right foot

- ⇒ Test voltage: 40 V
- ⇒ Steel pushbutton for testing
- ⇒ Wrist Strap connection: 4 mm banan plug or 10 mm snap-fastener
- ⇒ Relay Output to open Entrance gate: 0,5A/60V
- ⇒ Power supply: 12V DC
- ⇒ Size: 215 x 195 x 65 mm



AIJGO-22/ALU



AIJGO-22/ALU + AIJGO-22/STA

ORDER CODE

AIJGO-22/ALU Footwear & Wrist Strap Tester with Dual Foot Electrode

AIJGO-22/STA Stand for AIJGO-22/ALU

AIJGO-22LB/ALU LIGHT BAR Footwear & Wrist Strap Tester with Dual Foot Electrode

The AIJGO-22LB/ALU is an easy usable Footwear & Wrist strap tester with LIGHT BAR system to entrance of EPA area. It is an ideal solution for high volume of entrances where the quickness and safety is very important. High damaging-resistant construction with touch-button. It is versatile tester because you can choose the right measuring methods according to entrance regulation: Only footwear testing or footwear and wrist strap combined testing. You have to make only one test at the same time for the left and right foot because of the dual foot electrode. It can be connected to any kind of entrance gate (tripod turnstile, swing gate, wing barrier,...) with a relay output. It can be installed on the wall or with stand to the floor.

- ⇒ Footwear and Wrist Strap Tester for ESD area entrance
- ⇒ Both foot and wrist strap testing at the same time
- ⇒ Dual foot electrode to test the right and left foot separately
- ⇒ Test selector: Only footwear testing or Footwear and wrist strap combined testing
- ⇒ Resistance limits set by Software:

Footwear: 100 K Ω - 35 M Ω - Wrist Strap: 750 K Ω - 35 M Ω

- ⇒ Compliance with IEC 61340-5-1 and ANSI/ESD S20.20
- ⇒ Light (LED) and sound signal for the pass and faulty test, results separately:

Wrist Strap - Left foot - Right foot

- ⇒ Test voltage: 40 V
- ⇒ Wrist Strap connection: 4 mm banan plug or 10 mm snap-fastener
- ⇒ Relay Output to open Entrance gate: 0,5A/60V
- ⇒ Power supply: 12V DC
- ⇒ Size: 215 x 195 x 65 mm



AIJGO-22LB/ALU

LIGHT BAR
s y s t e m



AIJGO-22LB/ALU + AIJGO-22LB/STA

ORDER CODE

AIJGO-22LB/ALU Footwear & Wrist Strap Tester with Dual Foot Electrode

AIJGO-22LB/STA Stand for AIJGO-22/ALU

AIJGO-22LB/COMP LIGHT BAR & COMPLEX ESD Entrance System

The AIJGO-22LB/COMP is an „all in one“ ESD entrance solution: AIJGO-22LB/ALU Footwear & Wrist Strap Tester with Dual Foot Electrode + AS 110 Entrance gate

The AIJGO-22LB/ALU is an easy usable Footwear & Wrist strap tester with LIGHT BAR system to entrance of EPA area. It is an ideal solution for high volume of entrances where the quickness and safety is very important. High damaging-resistant construction with touch-button. It is versatile tester because you can choose the right measuring methods according to entrance regulation: Only footwear testing or footwear and wrist strap combined testing. You have to make only one test at the same time for the left and right foot because of the dual foot electrode. COMPLEX system: The AIJGO-22LB/ALU tester is build in our AS110 tripod turnstile.

- ⇒ Footwear and Wrist Strap Tester for ESD area entrance
- ⇒ LIGHT BAR system with sound to signal for the pass and faulty test, results separately:

Wrist Strap - Left foot - Right foot

- ⇒ Both foot and wrist strap testing at the same time
- ⇒ Dual foot electrode to test the right and left foot separately
- ⇒ Test selector: Only footwear testing or Footwear and wrist strap combined testing
- ⇒ Resistance limits set by Software:

Footwear: 100 K Ω - 35 M Ω - Wrist Strap: 750 K Ω - 35 M Ω

- ⇒ Compliance with IEC 61340-5-1 and ANSI/ESD S20.20
- ⇒ Test voltage: 40 V
- ⇒ Wrist Strap connection: 4 mm banan plug or 10 mm snap-fastener
- ⇒ Power supply: 220V DC



AIJGO-BAR1

LIGHT BAR
s y s t e m

COMPLEX
s y s t e m

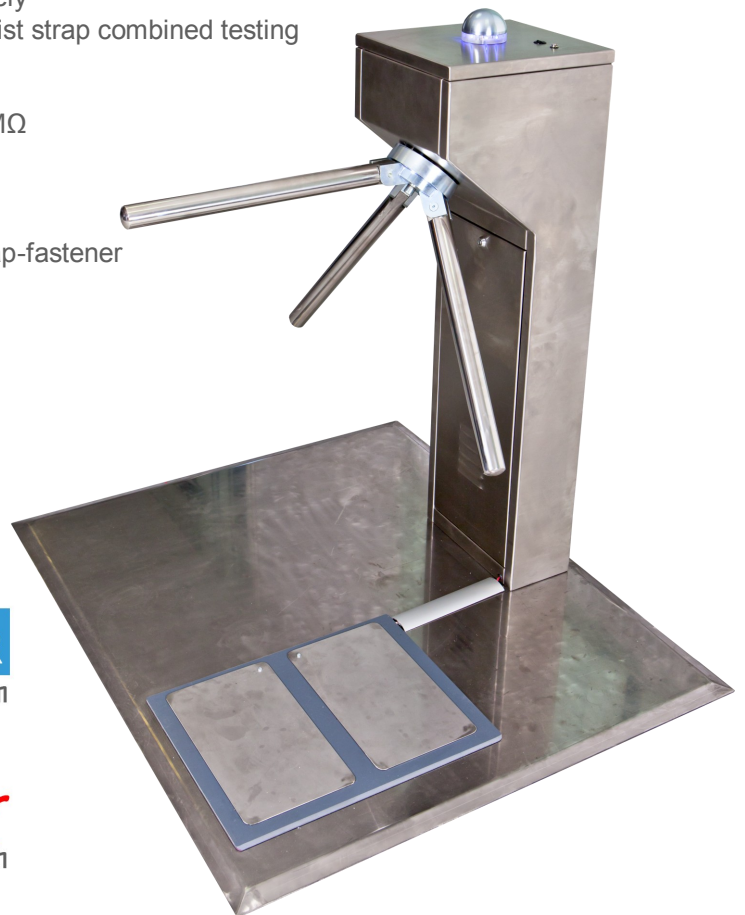

AIJGO-22LB/COMP

ORDER CODE

AIJGO-22LB/COMP LIGHT BAR & COMPLEX Footwear & Wrist Strap Tester with Dual Foot Electrode + AS110 Entrance gate

AIJGO-BAR1 Barrier for AIJGO22LB/COMP

AIJGO-31LB/ALU LIGHT BAR & COMFORT Footwear & Wrist Strap Tester with Dual Foot Electrode + RFID reader + Management software

The AIJGO-31LB/ALU is an easy usable Footwear & Wrist strap tester with LIGHT BAR & COMFORT system to entrance of EPA area.

* The Management Software has to be ordered together with the AIJGO-31LB/ALU but if more testers are connected a network in this case please do not hesitate to contact us with your network plan for a quotation!

LIGHT BAR system

It is an ideal solution for high volume of entrances where the quickness and safety is very important. High damaging-resistant construction with touch-button.

COMFORT system

This tester provides very easy entrance with RFID reader which make the personal identification and transfer the data (personal and measuring data) to a PC. The Management software handles the personal identification, test methods and results. The data can be read and saved from the PC. If the PC is connected to LAN network, the Management software is available on the internet. Many AIJGO-31LB/ALU testers are possible to be connected a network.

It is versatile tester because you can choose the right measuring methods by the Management software personally with the (Personal Chip Card) according to entrance regulation: Only footwear testing or footwear and wrist strap combined testing or VIP. You have to make only one test at the same time for the left and right foot because of the dual foot electrode. It can be connected to any kind of entrance gate (tripod turnstile, swing gate, wing barrier,...) with a relay output. It can be installed on the wall or with stand to the floor.

Main properties

- ⇒ Footwear and Wrist Strap Tester for ESD area entrance
- ⇒ LIGHT BAR system with sound to signal for the pass and faulty test, results separately:

Wrist Strap
Left foot
Right foot

- ⇒ Both foot and wrist strap testing at the same time
- ⇒ Dual foot electrode to test the right and left foot separately
- ⇒ Resistance limits set by Software:

Footwear: 100 K Ω - 35 M Ω
Wrist Strap: 750 K Ω - 35 M Ω

- ⇒ Compliance with IEC 61340-5-1 and ANSI/ESD S20.20
- ⇒ Test voltage: 40 V
- ⇒ Wrist Strap connection: 4 mm banan plug or 10 mm snap-fastener
- ⇒ Relay Output to open Entrance gate: 0,5A/60V
- ⇒ Operation system: Windows 7
- ⇒ PC connection with RS 485
- ⇒ Power supply: 12V DC
- ⇒ Size: 215 x 195 x 65 mm

RFID reader

- ⇒ Reading distance: 2-5 cm
- ⇒ RF frequency: 125 KHz
- ⇒ ISO/IEC 10536
- ⇒ Flexible system, adaptable to the user system

Management Software

- ⇒ Save the entrance data to local .csv file (compatible with EXCEL and text editors)
- ⇒ Automatically cut now log file every day
- ⇒ Acceptance limits changeable

Complete system:

- ⇒ AIJGO-31LB/ALU Footwear and Wrist Strap tester with Dual Foot electrode + RFID reader
- ⇒ PC
- ⇒ CD with the Management Software and Drivers
- ⇒ AC adapter



AIJGO-31LB/ALU



AIJGO-31LB/ALU + AIJGO-31LB/STA

ORDER CODE

AIJGO-31LB/ALU	LIGHT BAR & COMFORT Footwear & Wrist Strap Tester with Dual Foot Electrode + RFID Reader + PC
AIJGO-31LB/SFW	Management Software for AIJGO-31LB/ALU
AIJGO-31LB/STA	Stand for AIJGO-31LB/ALU

AIJGO-31LB/COMP LIGHT BAR & COMFORT & COMPLEX ESD Entrance system

The AIJGO-31LB/COMP is an „all in one” ESD entrance solution: AIJGO-31LB/ALU Footwear & Wrist Strap Tester with Dual Foot Electrode + RFID reader + Management software + AS 110 Entrance gate:

* The Management Software has to be ordered together with the AIJGO-31LB/COMP but if more testers are connected a network in this case please do not hesitate to contact us with your network plan for a quotation!

LIGHT BAR system

It is an ideal solution for high volume of entrances where the quickness and safety is very important. High damaging-resistant construction with touch-button.

COMFORT system

This tester provides very easy entrance with RFID reader which make the personal identification and transfer the data (personal and measuring data) to a PC. The Management software handles the personal identification, test methods and results. The data can be read and saved from the PC. If the PC is connected to LAN network, the Management software is available on the internet. Many AIJGO-31LB/ALU testers are possible to be connected a network.

COMPLEX system

The AIJGO-31LB/ALU tester is build in our AS110 tripod turnstile. This „all in one” construction is available in 3 version:

Without monitor

With monitor

With touch-screen monitor with build-in PC

It is versatile tester because you can choose the right measuring methods by the Management software personally with the (Personal Chip Card) according to entrance regulation: Only footwear testing or footwear and wrist strap combined testing or VIP. You have to make only one test at the same time for the left and right foot because of the dual foot electrode.

Main properties

- ⇒ Footwear and Wrist Strap Tester for ESD area entrance
- ⇒ LIGHT BAR system with sound to signal for the pass and faulty test, results separately:

Wrist Strap
Left foot
Right foot

- ⇒ Both foot and wrist strap testing at the same time
- ⇒ Dual foot electrode to test the right and left foot separately
- ⇒ Resistance limits set by Software:

Footwear: 100 K Ω - 35 M Ω
Wrist Strap: 750 K Ω - 35 M Ω

- ⇒ Compliance with IEC 61340-5-1 and ANSI/ESD S20.20
- ⇒ Test voltage: 40 V
- ⇒ Wrist Strap connection: 4 mm banan plug or 10 mm snap-fastener
- ⇒ Operation system: Windows 7
- ⇒ PC connection with RS 485
- ⇒ Power supply: 220V DC

RFID reader

- ⇒ Reading distance: 2-5 cm
- ⇒ RF frequency: 125 KHz
- ⇒ ISO/IEC 10536
- ⇒ Flexible system, adaptable to the user system

Management Software

- ⇒ Save the entrance data to local .csv file (compatible with EXCEL and text editors)
- ⇒ Automatically cut now log file every day
- ⇒ Acceptance limits changeable

Complete system:

- ⇒ AIJGO-31LB/ALU Footwear and Wrist Strap tester with Dual Foot electrode + RFID reader
- ⇒ PC
- ⇒ CD with the Management Software and Drivers
- ⇒ AC adapter



AIJGO-31LB/COMP2 + AIJGO-BAR1

ORDER CODE

AIJGO-31LB/COMP1	LIGHT BAR & COMFORT & COMPLEX Footwear & Wrist Strap Tester with Dual Foot Electrode + RFID Reader + PC + AS110 Entrance gate
AIJGO-31LB/MON	Monitor for AIJGO-31LB/COMP1
AIJGO-31LB/COMP2	LIGHT BAR & COMFORT & COMPLEX Footwear & Wrist Strap Tester with Dual Foot Electrode + RFID Reader + Touch-screen monitor with PC + AS110 Entrance gate
AIJGO-31LB/SFW	Management Software for AIJGO-31LB/ALU
AIJGO-BAR1	Barrier for AIJGO31LB/COMP